



PRODUCT NAME	MODEL NO. ALV710U3-QC7
Multi-function Intrinsic solenoid valves of Aluminum	
DESCRIPTION OF THE PRODUCT	
<p>The multi-function flameproof solenoid valves of aluminum is available with both Namur connection and In-line connection and also is easily switched between 3/2 and 5/2 for the same valve body. The flow rate of the valve is relatively large, and the air port can be selected between 1/4 and 1/2. Armed with aluminum enclosure coil, this solenoid valve is excellent for being used in hazardous area (Ex ia IIC T6 Ga).</p>	

APPROVED BY	Coil Specification: QC7 (ALV110Q1C7)		
	Coil Enclosure	Die-casting aluminum + Epoxy coated	
	Wiring Connector	M20-1.5 or 1/2"NPT, Terminal Strip	
BODY TECHNICAL DATA	Operating Voltage	12.5~24VDC (0.25~1.0W) at -20~60°C 13.5~24VDC (0.31~1.0W) at -40~60°C	
	Spool valve/Body	Extruded aluminum + anodized coated	
	Seal	Buna N	
	Fasteners	Stainless steel	
	Insulation Protection	H Class	
Function	5/2 and 3/2NC, Pilot acting, Monostable	Duty factor	100% ED
Manual Override	on the body	Area Classification	Ex ia IIC T6 Ga, Ex ia IIIC T85°C Db

Air Ports	G1/4" or NPT (optional 1/2")	Supply Specifications for Coil of C7	
Flow rate	CV = 1.7 (30mm ²)	U max : in	30VDC
Mounting	Namur mounting & In-line	I max : in	650mA
Working Medium	≤ 40µm filtered and dried air	W max : in	2980mW
Working Temp.	-20°C~60°C (optional: -40°C~60°C)	C max : in	0
Wiring direction	Front wiring	L max : in	0

Wiring connection instructions

As shown below, the coil C7 must be connected individually to an approved safety barrier. Placed in safe zone, these safety barriers can be used to supply ATEX pilot coil C7 installed in a hazardous zone. The electrical connection between the safety barrier (or interface) and the pilot coil C7 can be made using ordinary wires or cables. The inductance of the connecting line between the safety barrier and the pilot coil C7 must be less than 0.5mH.

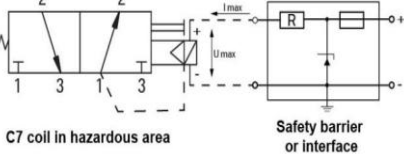

C7 coil in hazardous area Safety barrier or interface

Wiring Operating

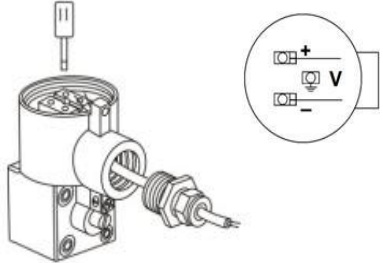

DRAWING AND MOUNTING

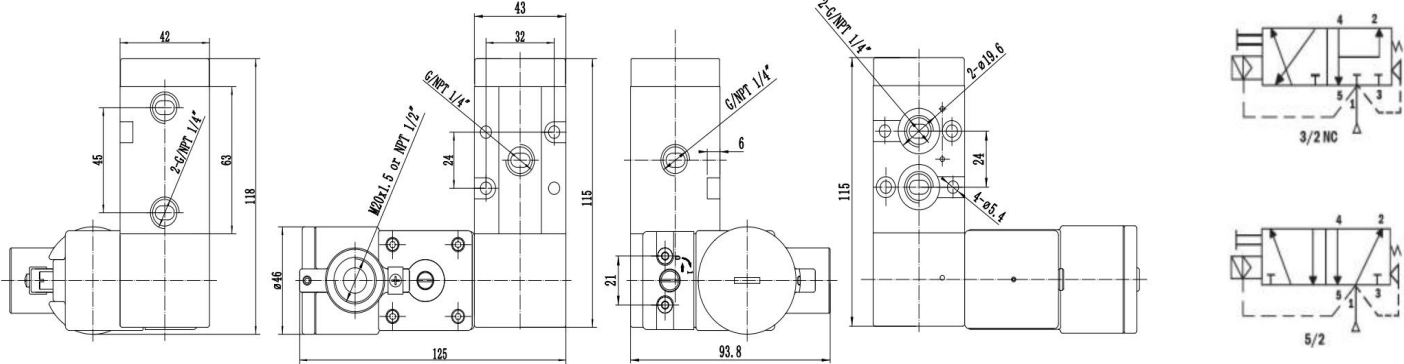

*For continuous improvement of the product, we reserve the right to alter the dimensions, technical data in this data sheet.